

Thank you for purchasing our electric wiper conversion kit for 55-57 Thunderbirds with 12 volt systems. We feel this is an excellent upgrade for the Little Birds. We have installed this electric wiper kit in our own shop and have found it to be very reliable. If you have any questions or comments please contact our technical assistance line at 740/622-9700.

Electric Wiper Kit Installation Instruction - '55-'57 T-Birds

Please read and understand all instructions before proceeding with the installation of this wiper kit.

This kit has been carefully engineered for quiet, proper reliable action. It is a two-speed unit, utilizing a "FoMoCo" dynamic parking motor. Installation requires no permanent modification; no holes need be drilled. The existing wiper control knob and trim and utilized. The self-contained conversion unit replaces the vacuum motor at the same location. Oilite Bearings are used throughout, assuring long life and maintenance-free operation. No lubrication is required.

Your new electric wiper conversion kit includes the following items. Please check to make sure all pieces are in the kit before beginning installation.

- Switch assembly with 15 amp fuse link
- Electric motor assembly with attaching sems nuts
- Rubber grommets, oilite bearings, spring retainer (on motor assembly)
- In envelope - 10/32 hex nut, 10-32x3/8 screw and vacuum plug

You will find that by providing more dependable action, independent of engine speed and vacuum, your Thunderbird's wet weather safety and driving pleasure will be enhanced. We are certain that you will enjoy this unit as much as we have enjoyed making it available.

Installation instructions

1. PREPARATION

Before proceeding, carefully examine and familiarize yourself with the existing wiper unit configuration, the electrical conversion unit, and these instructions and illustrations. Read and understand all the instructions and notes. This installation requires neither special skills nor tools, only patience and manual dexterity. Although this unit was designed for easiest possible installation, you will find that it must necessarily be placed in an already crowded area.

1. In order to avoid blown fuses and damage to electrical systems disconnect the battery cable at the positive battery terminal.
2. Remove wiper arm and blade assembly from outside the car.
3. Remove the radio and defroster duct from the driver's side defroster outlet in order to provide access to the working area.
4. The turn signal flasher unit and bracket must be re-located to provide clearance for the electric wiper control switch. See Figure 1.
The flasher unit is mounted horizontally behind the mechanical wiper switch. Un-snap the unit from the bracket and remove the screw that secures the bracket. Relocate the bracket, to a vertical position at the underside of the dash to the existing hole 2" to the right of the edge of the hood release handle bracket. Attach using the provided 10-32 screw and nut with the screw pointing downward through the bracket. Snap the flasher into the bracket.

2. REMOVAL OF VACUUM UNIT AND MECHANICAL SWITCH

1. Loosen set-screw on side of wiper control knob- remove knob. Unscrew and remove chrome plated collar at the center of the bezel and through which the switch shaft passes. Remove bezel and center.
2. Remove spring retainer which secures arms to motor. This is done by moving retainer away from the motor and toward firewall. Slip ends of arms off the motor.

NOTE: When working with spring retainers be careful to hang on to the retainer when installing or removing them because it is easy for this part to fall behind the firewall pad.

3. Remove vacuum hose between "Tee" fitting and motor. Block off open end of "Tee" with cap provided. Note: Original '57's with windshield washers have a cable mechanism between the vacuum motor and the foot- operated washer bellows. Remove and discard this cable.

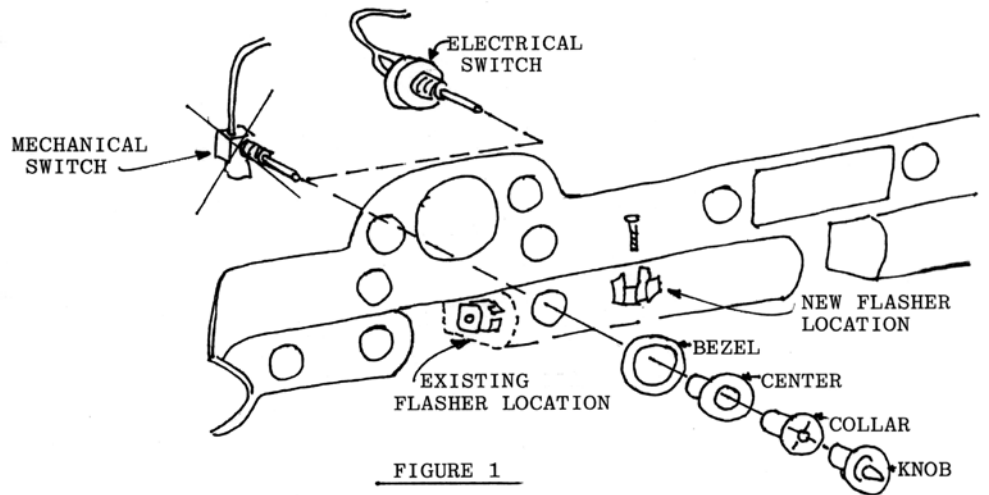

FIGURE 1

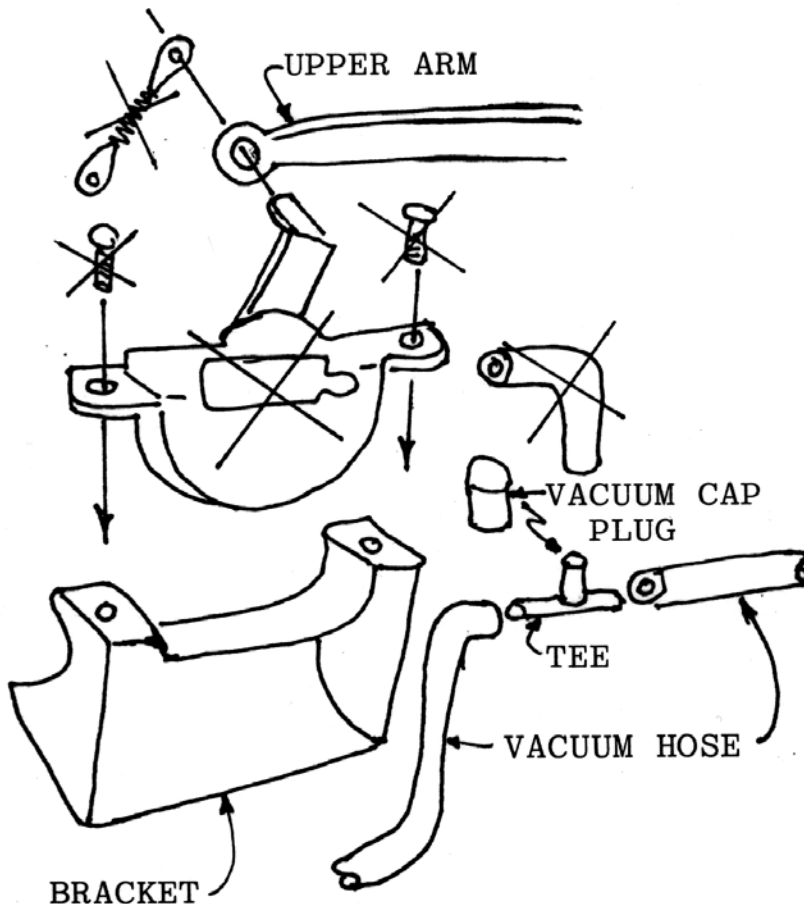

FIGURE 2

4. Remove the two nuts that secure the vacuum motor to the mounting bracket. Lift out and remove motor and switch.

5. Replace old grommets in wiper arms with new grommets provided.

3. INSTALLATION OF ELECTRIC WIPER KIT

1. Put olive bearings in grommets. These should fit snug in grommets so they don't drop out when arms are installed onto electric motor. This kit includes replacement rubber grommets to be used if the originals are poor condition or missing all together.
2. Install electric motor assembly. Leave nuts loose so you can install arms easier.

3. Install arms onto electric motor assembly. NOTE: The upper post on the electric motor must be attached to the RH (passenger) side arm. The driver side arm is attached to the lower post, the post without a link going to the motor.

4. Install spring retainer clip. Double check that the retainer is secure on both posts.

5. Tighten nuts which hold motor assembly in place.

Note: Cars equipped with windshield washers: During installation, avoid interference between wiper control arms and washer nozzle fittings in cowl. When unit is in place, secured, and arms attached, check for contact between arms and nozzles. In some cases it may be necessary to slightly bend the small inlet tube away from the arm to gain clearance. Use caution, do not break tube.

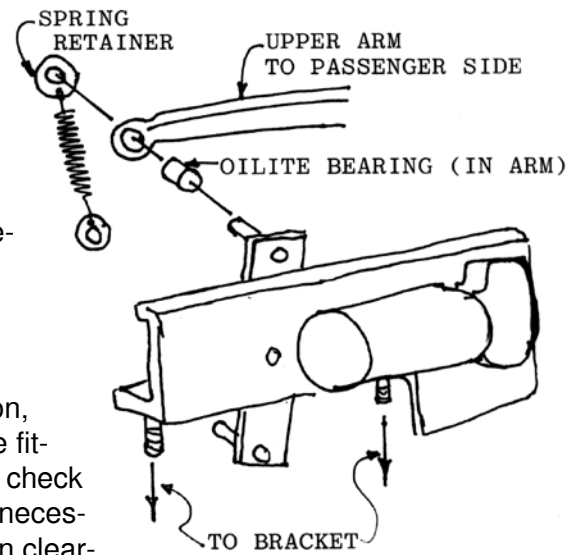

FIGURE 3

Note: All Cars: Carefully examine the area under the dash adjacent to the motor unit and arms. Make certain the no hoses, cables, wiring, or anything else is between the motor unit and the firewall and that nothing will otherwise interfere with the action of the motor unit or the wiper control arms. Check the position of the firewall insulator pad in the area below the crank on the motor. It may be necessary to fold or cut away a small portion of the pad.

6. Install switch assembly in dash. This kit is designed to use your original knob. The switch is mounted in exactly the same manner as the mechanical unit previously removed. Make certain that the flat portion of the shaft is aligned with the corresponding shape of the mounting hold in the dash. Apply bezel, center , and threaded collar, apply knob. Turn knob, make certain switch is in the "off" position (counter-clockwise). There are three positions. See Figure 1.

CAUTION: This electric wiper motor uses a worm gear configuration which provides high stall torque's. Be sure hands are not in linkage when unit is connected to electric.

7. The "hot" wire should be connected to the accessory post/terminal on the ignition switch. The accessory post will be the longest post. "ACC" will be in the plastic beside the accessory post. If you are using a test light or similar to check which post is correct, the ACC post will be hot in either position "ON" or "ACC"

8. Plug motor assembly harness into switch assembly harness

9. Connect battery, test wipers. After checking for interferences under the dash, observe the action of the wiper arm posts from the hood area. Confirm that the driver side post moves from the park position and rotates clockwise and returns counter-clockwise to the park position when stopped Re-check for interference.

10. Park motor

11. Replace radio and defroster duct

12. Reinstall wiper arm and blade assemblies

NOTES ON ELECTRIC WIPER CONVERSION KIT WITH SQUIRTER OPTION

* **Do not run squirter** for longer than a few seconds at a time without washer fluid in the pump.

* Electric washer motor can be used with or without and operating foot pedal

* Washer motor is mounted on the electric wiper assembly and is connected to washer hose just before the "T" which feeds the two jets mounted on the cowl

* If no operating foot pedal is to be used; cap off lower tube on valve in cap of washer bag with cap plug provided

* If you plan to use an operating washer pedal connect electric squirter as shown in Figure 4. Foot pedal will still work through electric pump. You do not need to cap off lower tube on washer bag which goes to foot pedal

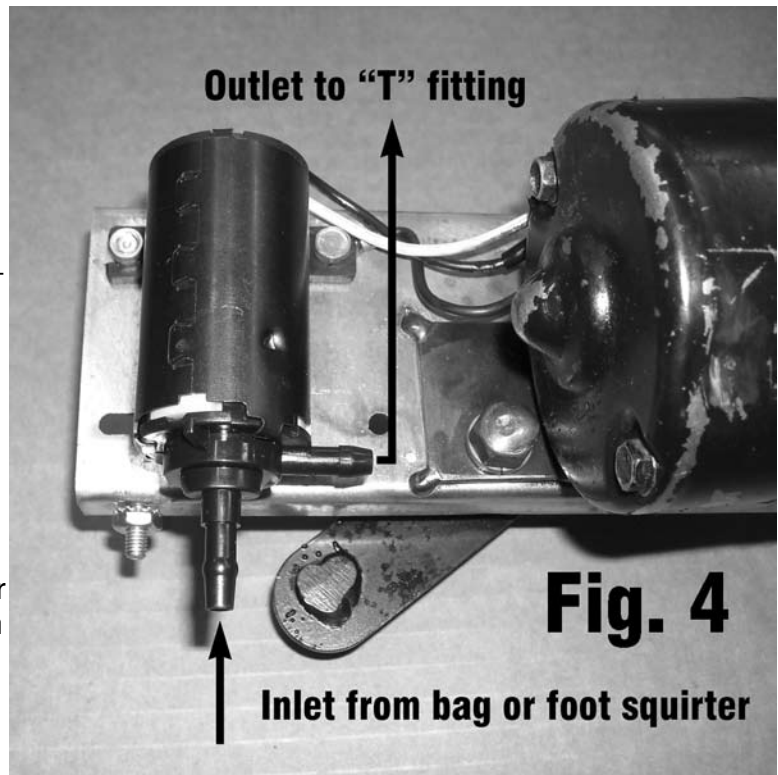

* When attaching hose to squirter, be sure hose is not kinked and is clear of wiper linkage. You may need to cut a piece out of the existing hose where the electric pump is in order to make a neat installation. When attaching hose on the inlet to squirter pump you may need to "soften" hose a bit by kneading hose with a pair of pliers several times

* When installing wiper knob, be sure to leave enough gap between knob and bezel so that the electric pump will energize when the knob is depressed

NOTES ON ELECTRIC WIPER CONVERSION KIT WITH INTERMITTENT OPTION

- * Rotating the knob clockwise from the off position will engage the intermittent option.
- * Continuing to rotate the knob clockwise will decrease the delay interval.
- * The Low and High speed settings are in detent position located after the delay range.
- * Pushing in the knob activates the washer pump if installed.
- * For light mist pushing in the knob will cause the wipers to wipe 2-3 times and stop.

