

INSTALLATION TIPS - WINDSHIELD WASHER KIT

17664CR PUMP MOUNTS THROUGH HOLE IN LH FIREWALL SUPPORT AS SHOWN

17651CR IS MOUNTED ON LH APRON. IT IS CENTERED WITH LH SHOCK ANCHOR AND THE CREASE IN 17651CR SHOULD BE ABOUT 1/8" ABOVE THE CREASE IN THE APRON

17651BR IS POSITIONED AS FOLLOWS. - ATTACH 17618 WASHER BAG TO 17651BR AND POSITION SUCH THAT THE BOTTOM OF THE 17618 WASHER BAG IS APPROXIMATELY 1/8" ABOVE THE LOWER EDGE OF 17651CR LOWER PLATE AND THE BAG SHOULD BE CENTERED ON THE 17651CR PLATE

NOTE ORIGINAL LH APRON MAY HAVE DETENTS OR PUNCHED HOLES WHERE 17651BR AND 17651CR ARE TO MOUNT

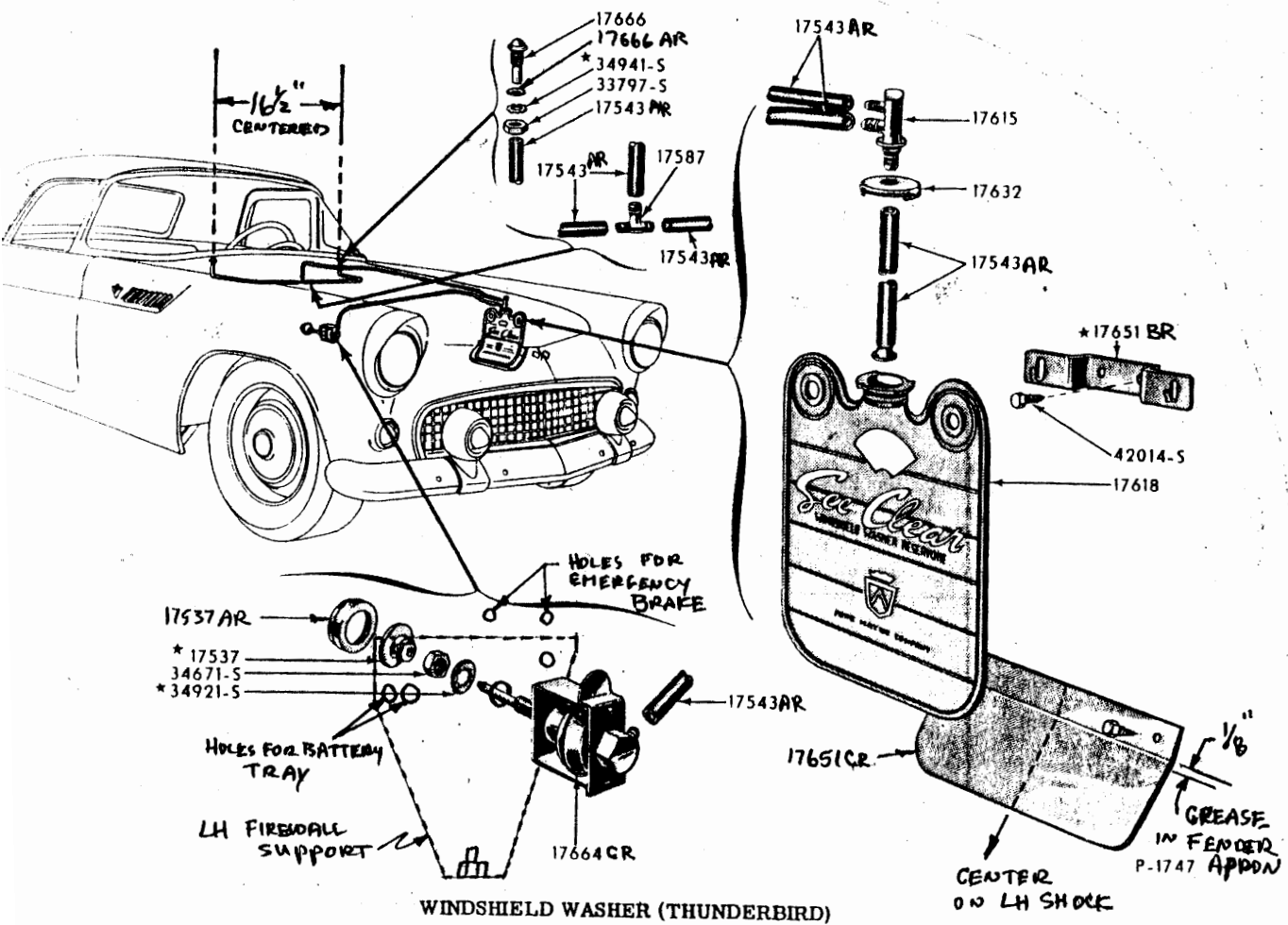

Windshield Washer Nozzle Location:

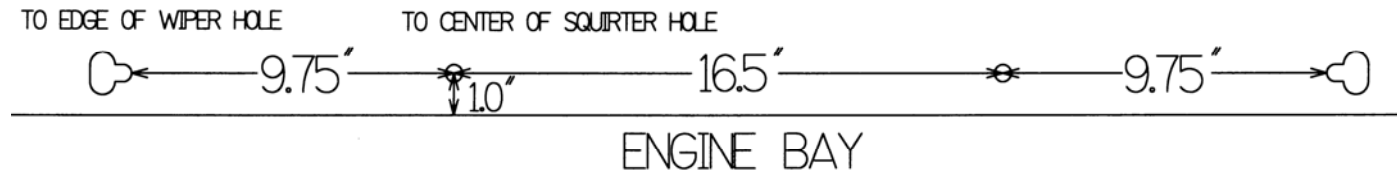

Measure 9.75" (9 $\frac{3}{4}$ ") from the edge of the wiper pivot hole and make a mark. Measure back from the edge of the engine bay 1" and make a mark. Where these two marks intersect, make a center punch and drill a .250" ($\frac{1}{4}$ ") hole.

Make the same measurements from the other wiper pivot hole, and drill the squirter hole. For your reference, the squirter holes should be 16.5 (16 $\frac{1}{2}$ ") center to center.

If you have questions please call our technical assistance hot line at 740/622-9700 