



## 1955-1957 Thunderbird 4-Bow Headliner Installation Guide

---

### Suggested Tools and Material Requirements for Installation:

- Staple Gun
  - Razor Blades
  - Phillips Head Screwdriver
  - Liquid Soap or Silicone Spray
  - 3/16" Staples
  - Contact Cement
  - 1/8" Nylon Rope
  - Unlimited Patience or Experience
  - Staple Pulling Tool
  - Steel Wool (Medium)
  - Shears
- 

1. Place hardtop upside down on a sturdy work table.
2. Remove chrome and stainless trim from all areas on and adjacent to the headliner.
3. Remove the rear glass, weatherstrip, and stainless trim as one complete unit. This can be done simply by lifting the rubber lip on the inside of the top and pushing outward on the glass unit from inside with the palm of the hand.
4. Carefully remove wire-on strip from the outer edge of the headliner. Take care when pulling staples, tacks, or screws from the tacking strip. Any breaks or loose areas in this strip will prevent proper installation of your new headliner.
5. Carefully remove staples from outer edge of headliner.
6. Lift bows from their seats.
7. Lift headliner from the top shell.
8. Inspect tacking strip for breaks or loose areas that will prevent new staples from holding the new headliner securely.
9. Replace fiberglass insulation if necessary. Secure new pad in place with contact cement.
10. Unfold new headliner and place it on a clean surface with smooth side up. Place light pencil marks where indicated in Figure 1. Inspect for any flaws before proceeding.
11. Turn headliner upside down. Lay old headliner out with bows up. Remove bows one at a time. Use steel wool to clean corrosion from the bow surface. This will be an important aid to installation. Place bow in new headliner listing strip exactly as it came out of the old strip. Be careful when sliding bow through listing strip so as not to cut material. When all bows are in place, position headliner in top shell with bows in their proper location.
12. Beginning at the rear of the top, install bows into retainer holes.
13. Working from the center of headliner, pull as much excess material as possible towards outer ends of bow seams.
14. Position the alignment marks as indicated in Figure 1. Use small clamps or glue to hold headliner in this position.

15. Moving to the front of the top, grasp the headliner at two points about one foot from either side of the centerline and pull the headliner toward the front tack strip. Secure the headliner at the center point with a few staples on both sides of the centerline.
16. Move to the front corners. Stretch the headliner into the corners and secure with staples.

**Note: For Porthole Tops, Follow Step 17A. For Non-Porthole Tops, Follow Step 17B.**

- 17a. Moving toward the back of the top, stretch all excess material toward the outer ends of the last (#4) bow. It will be necessary to puncture a hole in the bow listing to allow the bow to protrude through the listing. Insert bow ends into the seat provided at the top edge of the port hole. In order to pull the listing seam to the bottom edge of hardtop, a slit must be made where the bow protrudes through the listing (both ends). Cut in a longitudinal direction back toward the center of the headliner (Important - Cut only about 1" at a time). Stretch this seam to the lower tacking strip, keeping seam at approximate centerline of porthole. Secure in place with two staples. **DO NOT CUT HEADLINER FOR PORTHOLE AT THIS TIME.**
- 17b. Moving toward the back of the top, stretch all excess material toward the outer ends of the last (#4 bow). Insert bow ends into the seat provided at the bottom edge of hardtop. Secure in place with two staples.
18. Go back toward front of top securing each seam end to tacking strip. At this point of installation, the headliner should be tight from the fourth bow to the front of top.

**IMPORTANT:**

**DO NOT INSTALL THE ENTIRE LINE OF STAPLES YET.  
YOU MAY NEED TO REALIGN SEAMS TO REMOVE WRINKLES.**

19. Moving to the rear of the top, put contact cement on the area to be glued (See Figure 2). Apply adhesive to only one end of window opening at a time. Pulling excess material from the center, stretch the lower ends of the headliner to the bottom edge of the hardtop. Secure this point with staples to the tacking strip. Stretch headliner into place around rear glass opening. The glue applied earlier should be dry enough to stick by this time. This part of the installation procedure is sometimes a little difficult to get just right from the first time. Be patient and don't hesitate to remove staples or pull glued areas loose, and realign if necessary.
20. Secure the opposite side. When all wrinkles are gone, staple around entire perimeter of hardtop tacking strip. Place staples about 3/4" apart. Trim excess material from outer edge with a sharp razor blade.

**NOTE: For Non-Porthole Tops, Skip Step 21. Proceed to Step 22.**

21. Apply contact cement around the porthole flange and to corresponding area of headliner. Cut a circle out of the headliner about half of the diameter of the porthole. Bring the headliner into place around porthole flange. Secure the headliner to the flange carefully making relief cuts around the hole-cut made earlier. Trim with sharp razor blade.
22. A roll of wire-on trim is included with your Larry's Headliner Kit. This can be installed with staples or tacks and can be cut with wire cutters or shears. The wire-on is used to conceal staples and the rough edge of the new headliner. Install wire-on in the same manner as the old material.
23. Replace chrome and stainless trim pieces. The rear glass and weatherstrip unit can be easily reinstalled using a piece of 1/8" nylon rope inserted into the groove provided to secure rubber to top (Install this unit with stainless trim in the weatherstrip). Use liquid soap or silicone spray for lubrication.

(Figure 1)  
**4-Bow Headliner Layout**

- Step 1.** Measure from centerline, 15" each way. Place light pencil mark on seam line, at Points "A".
- Step 2.** Measure from the seam (on Centerline) 8 1/2" and place a light pencil mark at Point "B".
- Step 3.** Measure from the seam 8 1/4" and place a light pencil mark at two Points "C".

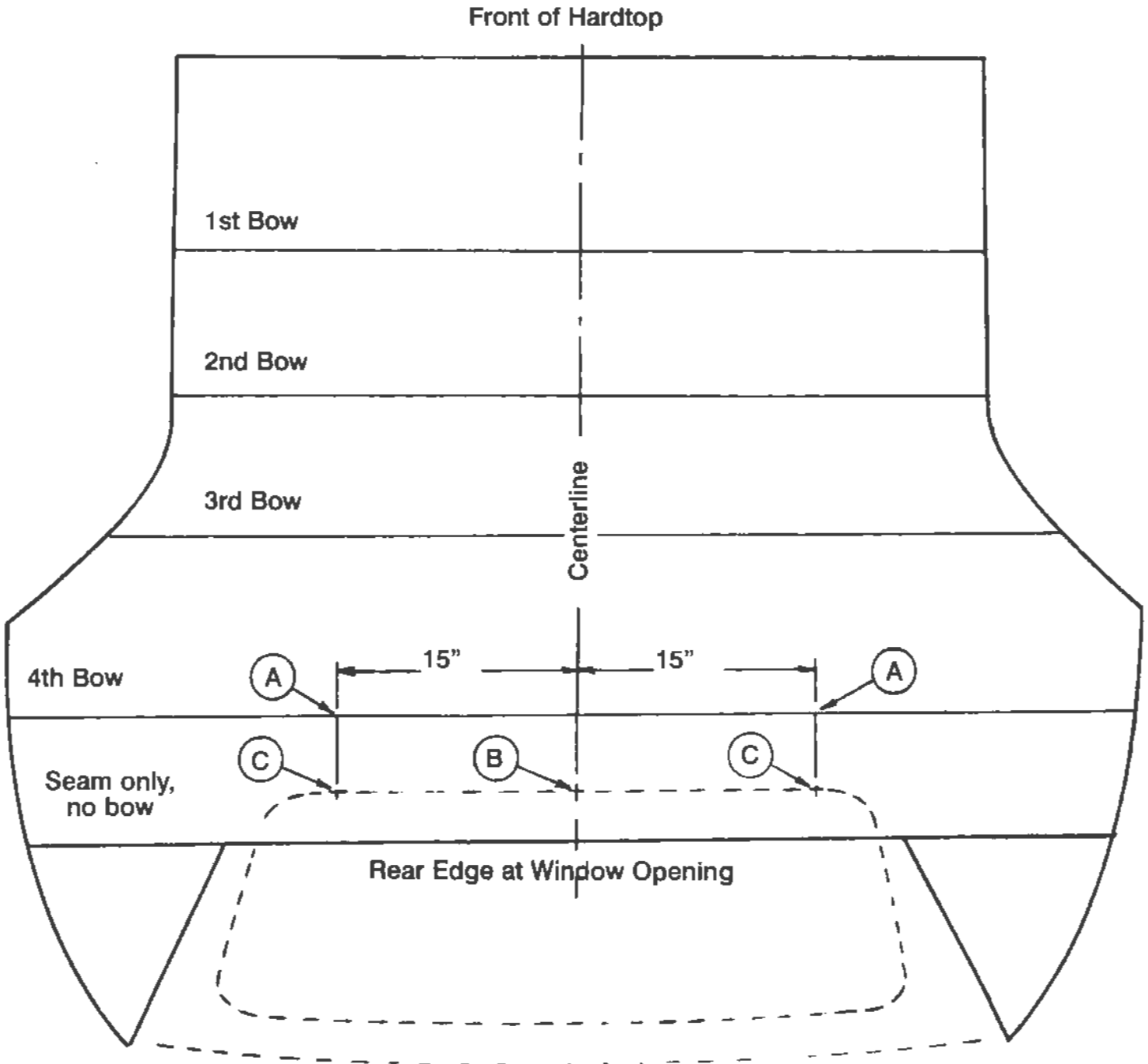

(Figure 2)  
Headliner Installation

